

## SPG100: 100mm (4") 100V 5W Twin Cone Driver



### Main Features

- \* Excellent speech intelligibility.
- \* Engineered to meet Australian Standard AS1670.4.
- \* High quality speaker driver developed for BGM, paging and emergency warning applications.
- \* Fitted with 4 way wire protect terminal block for loop in, loop out wiring as required by Australian Standards.
- \* Fitted with cable restraint plate and transformer safety cover as required by Australian Standards.
- \* Fitted with supervisory capacitor for line monitoring.
- \* 5 year warranty.

### Main Applications

The SPG100 is designed for general paging & EWIS (fire & evacuation) installations.

### Emergency Warning & Intercommunications Systems (EWIS)

This speaker and transformer combination is designed for both paging announcements and emergency tones in EWIS systems. Speakers employed in an EWIS installation must comply to AS1670.4. This dictates that the speakers must be fitted with transformer safety cover, line monitoring capacitor and 4 way wire protect terminal connection. These EWIS speakers comply to this standard.

### About Speaker Drivers

Each custom designed speaker and transformer combination has been specifically engineered to ensure a wide frequency range and dispersion angle, plus a high sound pressure level (SPL) ensuring excellent music and speech intelligibility; which is critical for emergency paging applications.

Each transformer is fitted with multiple power settings which are user selectable via taps on the transformer. For reference, the transformer safety cover is imprinted with power selection information.

### Manufacturing & Performance

Drivers are engineered and manufactured to stringent specifications ensuring maximum reliability under all operating conditions. Each driver has a power rating well above the max tapping of the transformer, ensuring reliable operation and excellent longevity. A strict quality control procedure is employed during every step of the manufacturing process. Finally, every finished speaker is 100% QC checked prior to shipping.

### Installation Guidelines

The SPG100 is fitted with a 4 way wire protect screw terminal block. This is suitable for loop in, loop out cabling. The cable can be secured to the in-built restraint plate with 100mm cable ties.

## Dimensions & Transformer Detail

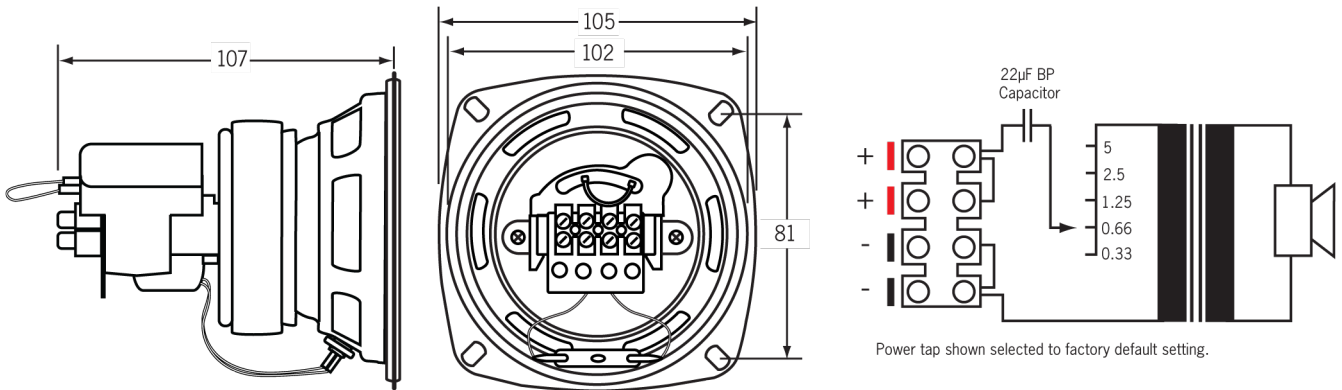

## Specifications

### Electrical

Power taps:	0.33, 0.66, 1.25, 2.5, 5W
SPL 1W @ 1m:	92.6dB @ 1kHz (+/- 2dB)
Frequency response:	100Hz-15kHz
Connection:	4 way terminal block + 22µF bipolar capacitor

### Mechanical

Driver construction:	Paper twin cone
Mounting depth:	107mm
Overall weight:	650g

### Environmental

Operating temperature:	-25°C to +55°C
Relative humidity:	< 95%

### Additional Installation Accessories

- C 0810 100mm (4") white ceiling grille
- C 0815 100mm (4") white slimline ceiling grille
- C 0816 100mm (4") black slimline ceiling grille
- C 0835 Pk100 speaker grille fixing clips
- C 0825 Pk100 Gypsee® gypsum/plasterboard screws

## Frequency Response (SPL 1W @ 1m)

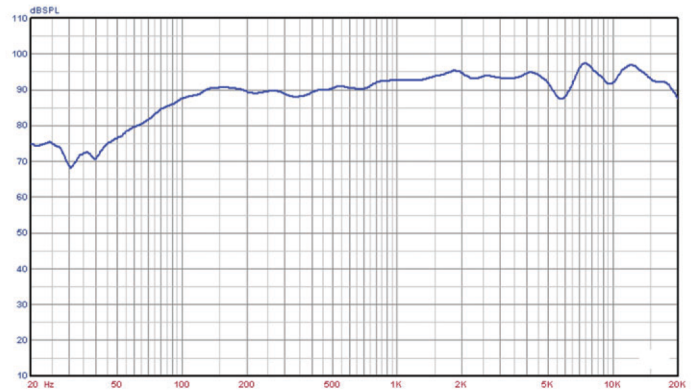

## Polar Plot (Ratio vs Angle)

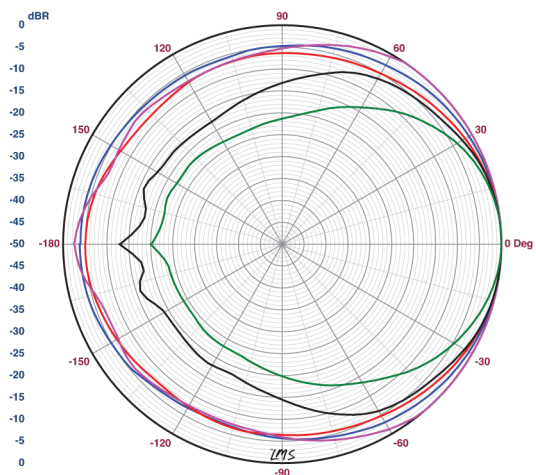

	500Hz	1kHz	2kHz	4kHz	6kHz
SPL 1W @ 1m (dB)	90.4	92.6	94.6	94.6	95.7
Beam Width (BW)	273	153	185	116	69
Q-Factor	1.3	2.4	1.9	3.1	5.2
Directivity Index (DI)	1.2	3.7	2.9	4.9	7.2